

AIEEE - 2009

Answers by
Aakash
IIT-JEE

(Division of Aakash Educational Services Ltd.)

CODES

Q.No.	A	B	C	D
01	2	1	4	1
02	1	4	4	1
03	3	2	4	1
04	1	3	3	1
05	2	3	2	4
06	1	1	1	2
07	4	1	4	1
08	3	1	4	1
09	4	2	4	1
10	2	1	3	4
11	4	2	1	4
12	2	4	4	4
13	2	3	4	4
14	3	3	3	1
15	4	2	2	3
16	2	2	4	3
17	2	2	3	1
18	2	1	3	1
19	3	1	4	1
20	1	2	1	4
21	2	2	2	4
22	4	2	3	1
23	4	2	3	2
24	1	1	3	4
25	4	1	4	2
26	1	1	1	4
27	4	3	3	2
28	3	2	3	1
29	2	2	2	2
30	2	2	2	4

CODES

Q.No.	A	B	C	D
31	3	2	1	4
32	4	1	2	3
33	3	2	3	4
34	3	3	4	4
35	3	2	3	2
36	3	2	3	3
37	4	1	1	3
38	4	4	4	4
39	3	1	2	3
40	4	3	2	1
41	3	4	1	4
42	3	1	4	4
43	3	2	2	2
44	2	2	3	4
45	2	3	4	2
46	4	2	3	2
47	2	1	1	2
48	1	4	2	4
49	1	2	3	1
50	2	1	3	1
51	2	2	3	3
52	2	2	4	3
53	3	4	1	1
54	2	1	3	4
55	2	2	1	4
56	3	1	1	4
57	3	1	1	1
58	2	1	3	2
59	2	4	3	2
60	3	3	2	2

CODES

Q.No.	A	B	C	D
61	3	2	4	4
62	3	4	3	4
63	3	1	4	1
64	3	3	1	1
65	2	1	3	2
66	3	1	4	3
67	1	2	3	2
68	2	1	4	4
69	4	1	4	4
70	4	4	4	2
71	3	4	3	3
72	1	1	4	3
73	2	3	1	1
74	3	3	4	4
75	2	3	4	4
76	2	2	3	1
77	2	1	4	2
78	2	1	4	1
79	2	3	3	1
80	4	1	2	3
81	1	4	3	1
82	1	3	3	4
83	3	3	3	4
84	2	1	4	1
85	1	4	1	1
86	3	1	1	3
87	3	3	2	4
88	4	4	3	4
89	3	2	4	1
90	2	2	1	1

Though every care has been taken to provide the answers correctly but the Institute shall not be responsible for error, if any.

Aakash
IIT-JEE

(Division of Aakash Educational Services Ltd.)

Regd. Office: Aakash Tower, Plot No.-4, Sector-11, Dwarka, New Delhi-110075 Ph: (011) 47623456, Fax: (011) 25084124. Distance Learning Program (DLP) / Correspondence Course Division: Aakash Tower, Plot No.-4, Sector-11, Dwarka, New Delhi-110075. Ph : (011) 47623417 / 423, Fax: (011) 25084124. **Janakpuri:** A-1/18, Janakpuri, Delhi-110058 Ph: 011-47011456. Fax No: 011-25514826 **South Delhi:** D-15, South Extension Part-II, New Delhi-110049 Ph: 011-43123234, 26261664 Fax: 011-24604230. **Noida:** K-4, 4th Floor, Ocean Heights, Sector-18, Noida, U.P. Ph: 0120-6475081/82, Fax: 0120-4227252. **Chandigarh:** S.C.O. 332-334, Top Floor, Sector-34A, Chandigarh-160009 Ph: (0172) 4333800/817, Fax: (0172) 4333820. **Dehradun:** Ballapur Chowk: 144, Usha Complex, GMS Road, Ballapur Chowk, Dehradun, Ph: 0135-3298167, 6455995 Fax: 0135-2724552. **Rajpur Road:** 69, Rajpur Road Dehradun Ph: 0135-3298168, 6455996, 2742120. Fax: 0135-2742181 **Mumbai:** **Andheri** 406, 4th Floor, Sagar Avenue (Near Shopper's Stop), SV Road, Andheri (West), Mumbai-400058. Ph: (022) 26256986/87 Fax: (022) 26256989 **Dadar:** 101-104, 1st Floor, Tirthankar Building, S.K. Bole Road, (Opp. Jain Health Centre), Dadar (W), Mumbai-400028. Ph: (022) 24321556/65 Fax: (022) 24311557 **Vashi** - 733-734, 3rd Floor, Tower 7, International Infotech Park (Above Vashi Station) Vashi, Navi Mumbai-400705 Ph: (022) 27814411/41, Fax: (022) 27814222. **Pune:** **Wanowrie**- 406, 4th Floor, South Block, Sacred World, Vithal Shivakar Marg, Wanowrie, Pune. Ph: (020) 26806577/88, Fax: (020) 26806544. **Vishrantwadi** - 113/4, Dataram Bhawan, 1st Floor, Alandi Road, Vishrantwadi, Pune. Ph: (020) 32542903.

TOP RANKERS ALWAYS FROM AAKASH

ANALYSIS OF PHYSICS PORTION OF AIEEE 2009

	XII	XI	XII	XI	XII	XII	XI	XI	
	Electricity	Heat & Thermodynamics	Magnetism	Mechanics	Modern Physics	Optics	Unit and Measurements	Waves	Total
Easy	2	2	0	2	2	2	0	0	10
Medium	2	2	2	2	2	0	1	1	12
Tough	1	1	1	2	1	1	0	1	8
Total	5	5	3	6	5	3	1	2	30

XI syllabus	14	XII syllabus	16
--------------------	----	---------------------	----

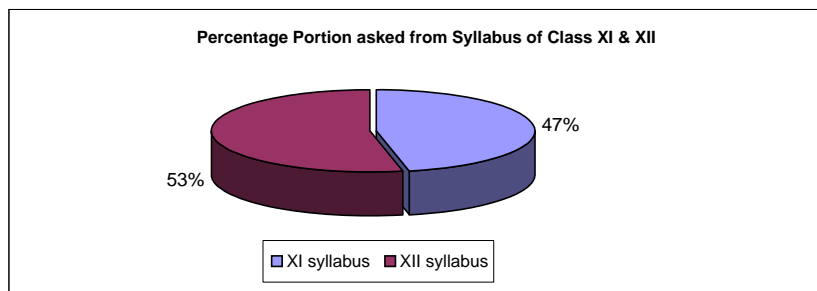
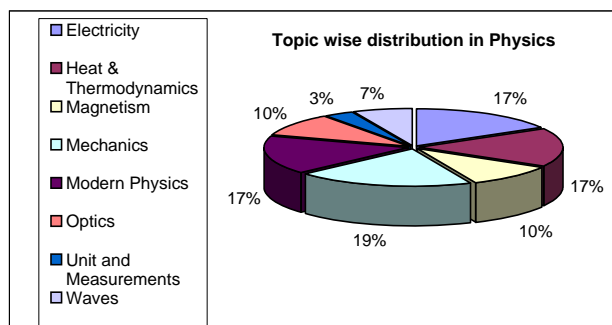
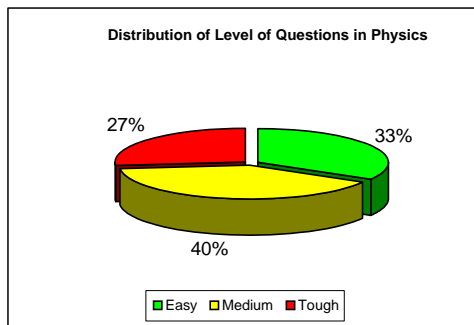

ANALYSIS OF CHEMISTRY PORTION OF AIEEE 2009

	Organic Chemistry	Inorganic Chemistry	Physical Chemistry	Total
Easy	3	0	2	5
Medium	7	6	9	22
Tough	0	3	0	3
Total	10	9	11	30

XI syllabus	14	XII syllabus	21
--------------------	-----------	---------------------	-----------

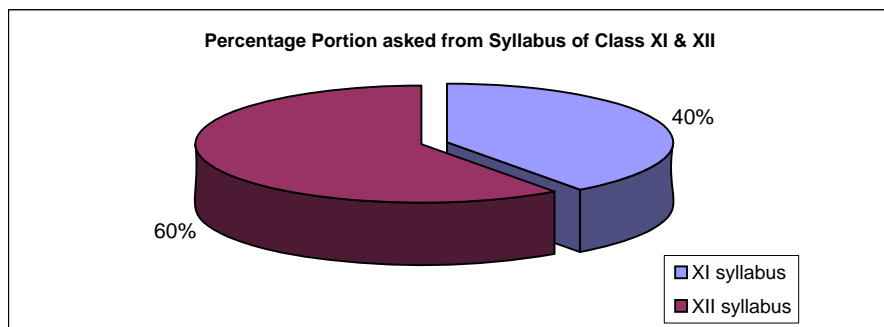
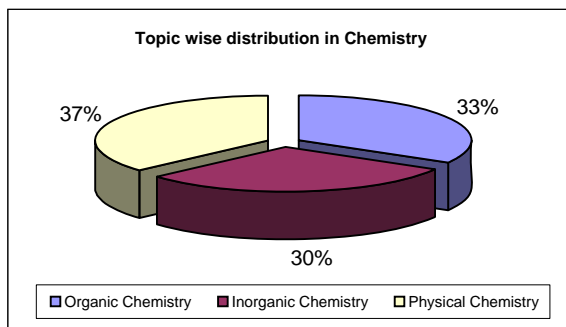
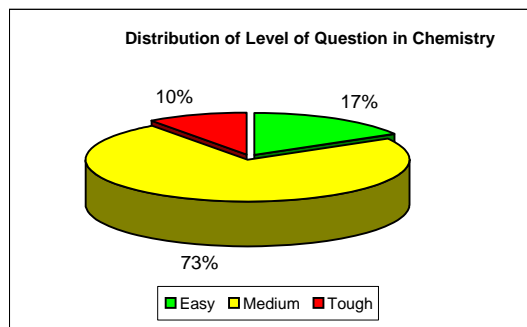

ANALYSIS OF MATHEMATICS PORTION OF AIEEE 2009

	XII	XI	XII	XI	XI	XII	XI	XII	XI	XII	Total
	Calculus	Trigonometry	Algebra (XII)	Algebra (XI)	Coordinate Geometry	Probability	Statistics	3-D (XII)	3-D (XI)	Vectors	
Easy	2	0	0	1	0	1	1	0	1	0	6
Medium	3	1	1	2	3	0	1	0	0	1	12
Tough	3	0	1	3	2	1	1	1	0	0	12
Total	8	1	2	6	5	2	3	1	1	1	30

XI syllabus	16	XII syllabus	14
-------------	----	--------------	----

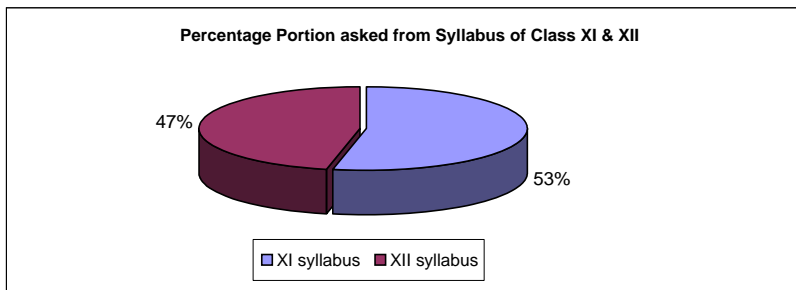
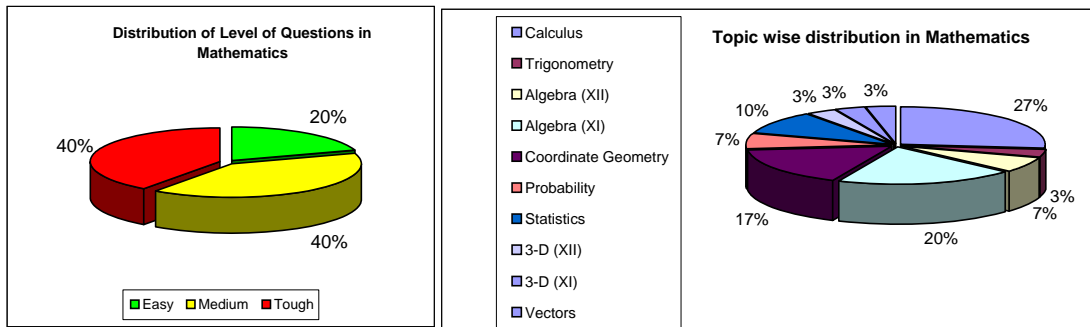

Dated : 26/04/2009

Aakash IIT-JEE

(Division of Aakash Educational Services Ltd.)

Regd. Office : Aakash Tower, Plot No.-4, Sec-11, MLU, Dwarka, New Delhi-110075
Ph.: 011-47623456 Fax : 011-25084124

Solutions of AIEEE 2009

Time : 3 hrs.

CODE - B

Max. Marks: 432

Chemistry, Mathematics & Physics

Important Instructions :

1. Immediately fill in the particulars on this page of the Test Booklet with Blue/Black Ball Point Pen. Use of pencil is strictly prohibited.
2. The Answer Sheet is kept inside this Test Booklet. When you are directed to open the Test Booklet, take out the Answer Sheet and fill in the particulars carefully.
3. The test is of **3 hours** duration.
4. The Test Booklet consists of **90** questions. The maximum marks are **432**.
5. There are **three** parts in the question paper. The distribution of marks subjectwise in each part is as under for each correct response.
Part A – CHEMISTRY (144 marks) – Question No. 1 to 24 consist **FOUR (4)** marks each and Question No. 25 to 30 consist **EIGHT (8)** marks each for each correct response.
Part B – MATHEMATICS (144 marks) – Question No. 31 to 32 and 39 to 60 consist **FOUR (4)** marks each and Question No. 33 to 38 consist **EIGHT (8)** marks each for each correct response.
Part C – PHYSICS (144 marks) – Questions No.61 to 84 consist **FOUR (4)** marks each and Question No. 85 to 90 consist **EIGHT (8)** marks each for each correct response
6. Candidates will be awarded marks as stated above in instructions No. 5 for correct response of each question. $\frac{1}{4}$ (one fourth) marks will be deducted for indicating incorrect response of each question. No deduction from the total score will be made if no response is indicated for an item in the answer sheet.
7. Use **Blue/Black Ball Point Pen only** for writing particulars/markings responses on **Side-1** and **Side-2** of the Answer Sheet **Use of pencil is strictly prohibited**.
8. No candidate is allowed to carry any textual material, printed or written, bits of papers, pager, mobile phone, any electronic device, etc. except the Admit Card inside the examination hall/room.
9. On completion of the test, the candidate must hand over the Answer Sheet to the Invigilator on duty in the Room/Hall, however the candidates are allowed to take away this Test Booklet with them.
10. The **CODE** for this Booklet is **B**. Make sure that the **CODE** printed on Side-2 of the Answer Sheet is the same as that on this booklet. In case of discrepancy, the candidate should immediately report the matter to the Invigilator for replacement of both the Test Booklet and the Answer Sheet
11. Do not fold or make any stray marks on the Answer Sheet.

PART - A : CHEMISTRY

1. The IUPAC name of neopentane is

- (1) 2, 2-dimethylpropane (2) 2-methylpropane
(3) 2, 2-dimethylbutane (4) 2-methylbutane

Answer (1)

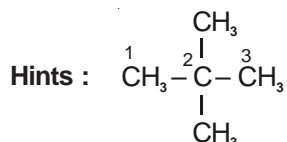

IUPAC name : 2, 2-dimethylpropane

2. Which one of the following reactions of Xenon compounds is **not** feasible?

- (1) $3\text{XeF}_4 + 6\text{H}_2\text{O} \rightarrow 2\text{Xe} + \text{XeO}_3 + 12\text{HF} + 1.5\text{O}_2$ (2) $2\text{XeF}_2 + 2\text{H}_2\text{O} \rightarrow 2\text{Xe} + 4\text{HF} + \text{O}_2$
(3) $\text{XeF}_6 + \text{RbF} \rightarrow \text{Rb}[\text{XeF}_7]$ (4) $\text{XeO}_3 + 6\text{HF} \rightarrow \text{XeF}_6 + 3\text{H}_2\text{O}$

Answer (4)

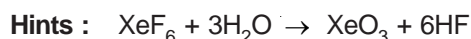

3. The major product obtained on interaction of phenol with sodium hydroxide and carbon dioxide is:

- (1) Salicylaldehyde (2) Salicylic acid
(3) Phthalic acid (4) Benzoic acid

Answer (2)

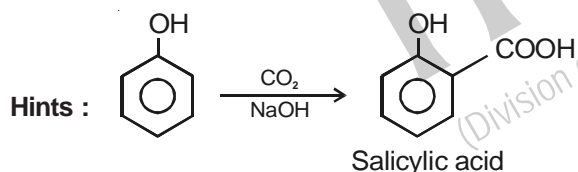

4. Which of the following statements is **incorrect** regarding physisorptions?

- (1) More easily liquefiable gases are adsorbed readily
(2) Under high pressure it results into multi molecular layer on adsorbent surface
(3) Enthalpy of adsorption ($\Delta H_{\text{adsorption}}$) is low and positive
(4) It occurs because of van der Waal's forces

Answer (3)

Hints : Physisorption is an exothermic process with $\Delta H \approx -20 \text{ kJ/mol}$

5. Which of the following has an optical isomer?

- (1) $[\text{Co}(\text{en})(\text{NH}_3)_2]^{2+}$ (2) $[\text{Co}(\text{H}_2\text{O})_4(\text{en})]^{3+}$
(3) $[\text{Co}(\text{en})_2(\text{NH}_3)_2]^{3+}$ (4) $[\text{Co}(\text{NH}_3)_3\text{Cl}]^+$

Answer (3)

Hints :

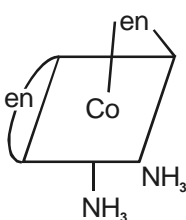
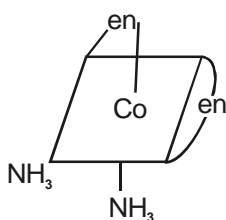

6. Solid $\text{Ba}(\text{NO}_3)_2$ is gradually dissolved in a $1.0 \times 10^{-4} \text{ M}$ Na_2CO_3 solution. At what concentration of Ba^{2+} will a precipitate begin to form? (K_{sp} for $\text{BaCO}_3 = 5.1 \times 10^{-9}$)

- (1) $5.1 \times 10^{-5} \text{ M}$ (2) $8.1 \times 10^{-8} \text{ M}$
(3) $8.1 \times 10^{-7} \text{ M}$ (4) $4.1 \times 10^{-5} \text{ M}$

Answer (1)

Hints : $[\text{CO}_3^{2-}] = 10^{-4} \text{ M}$

$$K_{\text{sp}} [\text{BaCO}_3] = [\text{Ba}^{2+}] [\text{CO}_3^{2-}]$$

$$\Rightarrow [\text{Ba}^{2+}] = \frac{K_{\text{sp}}}{[\text{CO}_3^{2-}]} = \frac{5.1 \times 10^{-9}}{10^{-4}} = 5.1 \times 10^{-5} \text{ M}$$

7. Calculate the wavelength (in nanometer) associated with a proton moving at $1.0 \times 10^3 \text{ ms}^{-1}$

(Mass of proton = $1.67 \times 10^{-27} \text{ kg}$ and $h = 6.63 \times 10^{-34} \text{ Js}$)

- (1) 0.40 nm (2) 2.5 nm
(3) 14.0 nm (4) 0.032 nm

Answer (1)

Hints : $\lambda = \frac{h}{p} = \frac{h}{mv}$

$$\text{or } \lambda = \frac{6.63 \times 10^{-34}}{1.67 \times 10^{-27} \times 10^3} = 0.4 \text{ nm}$$

8. In context with the transition elements, which of the following statements is **incorrect**?

- (1) In the highest oxidation states, the transition metals show basic character and form cationic complexes
(2) In the highest oxidation states of the first five transition elements (Sc to Mn), all the 4s and 3d electrons are used for bonding.
(3) Once the d^5 configuration is exceeded, the tendency to involve all the 3d electrons in bonding decreases
(4) In addition to the normal oxidation states, the zero oxidation state is also shown by these elements in complexes

Answer (1)

Hints : In the highest oxidation states, the transition metals show acidic character.

9. In an atom, an electron is moving with a speed of 600 m/s with an accuracy of 0.005%. Certainty with which the position of the electron can be located is ($h = 6.6 \times 10^{-34}$ kg m²s⁻¹, mass of electron, $e_m = 9.1 \times 10^{-31}$ kg)

- (1) 5.10×10^{-3} m (2) 1.92×10^{-3} m
(3) 3.84×10^{-3} m (4) 1.52×10^{-4} m

Answer (2)

Hints : $\Delta p \cdot \Delta x \geq \frac{h}{4\pi}$

$$\Delta x = \frac{h}{4\pi \cdot m\Delta v}$$

$$= \frac{6.6 \times 10^{-34} \times 100}{4 \times 3.14 \times 9.1 \times 10^{-31} \times 600 \times 0.005}$$

$$= 1.92 \times 10^{-3} \text{ m}$$

10. Which of the following pairs represents linkage isomers?

- (1) $[\text{Pd}(\text{P Ph}_3)_2(\text{NCS})_2]$ and $[\text{Pd}(\text{P Ph}_3)_2(\text{SCN})_2]$
(2) $[\text{Co}(\text{NH}_3)_5\text{NO}_3]\text{SO}_4$ and $[\text{Co}(\text{NH}_3)_5\text{SO}_4]\text{NO}_3$
(3) $[\text{PtCl}_2(\text{NH}_3)_4]\text{Br}_2$ and $[\text{PtBr}_2(\text{NH}_3)_4]\text{Cl}_2$
(4) $[\text{Cu}(\text{NH}_3)_4][\text{PtCl}_4]$ and $[\text{Pt}(\text{NH}_3)_4][\text{CuCl}_4]$

Answer (1)

Hints : SCN^- is an ambidentate ligand.

11. In bond dissociation energy of B-F in BF_3 is 646 kJ mol⁻¹ whereas that of C-F in CF_4 is 515 kJ mol⁻¹. The correct reason for higher B-F bond dissociation energy as compared to that of C-F is

- (1) Stronger σ bond between B and F in BF_3 as compared to that between C and F in CF_4
(2) Significant $p\pi - p\pi$ interaction between B and F in BF_3 whereas there is no possibility of such interaction between C and F in CF_4
(3) Lower degree of $p\pi - p\pi$ interaction between B and F in BF_3 than that between C and F in CF_4
(4) Smaller size of B-atom as compared to that of C-atom

Answer (2)

Hints : In BF_3 , F forms $p\pi - p\pi$ back bonding with B.

12. Using MO theory predict which of the following species has the shortest bond length?

- (1) O_2^+ (2) O_2^-
(3) O_2^{2-} (4) O_2^{2+}

Answer (4)

Hints : Higher is the bond order, shorter is the bond length.

Bond order of O_2^{2+} is 3.0

18. A binary liquid solution is prepared by mixing n-heptane and ethanol. Which one of the following statements is **correct** regarding the behaviour of the solution?

- (1) The solution is non-ideal, showing +ve deviation from Raoult's Law
- (2) The solution is non-ideal, showing –ve deviation from Raoult's Law
- (3) n-heptane shows +ve deviation while ethanol shows –ve deviation from Raoult's Law
- (4) The solution formed is an ideal solution

Answer (1)

Hints : Ethanol has H-Bonding, n-heptane tries to break the H-bonds of ethanol, hence, V.P. increases. Such a solution shows positive deviation from Raoult's Law.

19. The set representing the **correct** order of ionic radius is

- (1) $\text{Na}^+ > \text{Li}^+ > \text{Mg}^{2+} > \text{Be}^{2+}$
- (2) $\text{Li}^+ > \text{Na}^+ > \text{Mg}^{2+} > \text{Be}^{2+}$
- (3) $\text{Mg}^{2+} > \text{Be}^{2+} > \text{Li}^+ > \text{Na}^+$
- (4) $\text{Li}^+ > \text{Be}^{2+} > \text{Na}^+ > \text{Mg}^{2+}$

Answer (1)

Hints :



20. Arrange the carbanions, $(\text{CH}_3)_3\bar{\text{C}}$, $\bar{\text{C}}\text{Cl}_3$, $(\text{CH}_3)_2\bar{\text{C}}\text{H}$, $\text{C}_6\text{H}_5\bar{\text{C}}\text{H}_2$, in order of their decreasing stability

- (1) $(\text{CH}_3)_2\bar{\text{C}}\text{H} > \bar{\text{C}}\text{Cl}_3 > \text{C}_6\text{H}_5\bar{\text{C}}\text{H}_2 > (\text{CH}_3)_3\bar{\text{C}}$
- (2) $\bar{\text{C}}\text{Cl}_3 > \text{C}_6\text{H}_5\bar{\text{C}}\text{H}_2 > (\text{CH}_3)_2\bar{\text{C}}\text{H} > (\text{CH}_3)_3\bar{\text{C}}$
- (3) $(\text{CH}_3)_3\bar{\text{C}} > (\text{CH}_3)_2\bar{\text{C}}\text{H} > \text{C}_6\text{H}_5\bar{\text{C}}\text{H}_2 > \bar{\text{C}}\text{Cl}_3$
- (4) $\text{C}_6\text{H}_5\bar{\text{C}}\text{H}_2 > \bar{\text{C}}\text{Cl}_3 > (\text{CH}_3)_3\bar{\text{C}} > (\text{CH}_3)_2\bar{\text{C}}\text{H}$

Answer (2)

Hints :

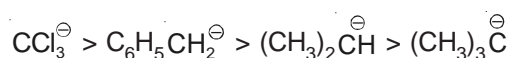

21. Knowing that the chemistry of lanthanoids (Ln) is dominated by its +3 oxidation state, which of the following statements is **incorrect**?

- (1) The ionic sizes of Ln (III) decrease in general with increasing atomic number
- (2) Ln (III) compounds are generally colourless
- (3) Ln (III) hydroxides are mainly basic in character
- (4) Because of the large size of the Ln (III) ions the bonding in its compounds is predominantly ionic in character

Answer (2)

Hints :

Ln (III) compounds are generally coloured.

22. The alkene that exhibits geometrical isomerism is

- (1) 2 - methyl propene (2) 2 - butene
 (3) 2 - methyl - 2 - butene (4) Propene

Answer (2)

Hints :

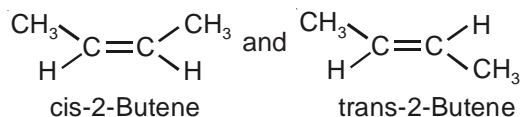

23. The number of stereoisomers possible for a compound of the molecular formula $\text{CH}_3-\text{CH}=\text{CH}-\text{CH}(\text{OH})-\text{Me}$ is

- (1) 2 (2) 4
 (3) 6 (4) 3

Answer (2)

Hints :

$\text{CH}_3\text{CH}=\text{CH}-\overset{*}{\text{C}}(\text{OH})\text{Me}$ has

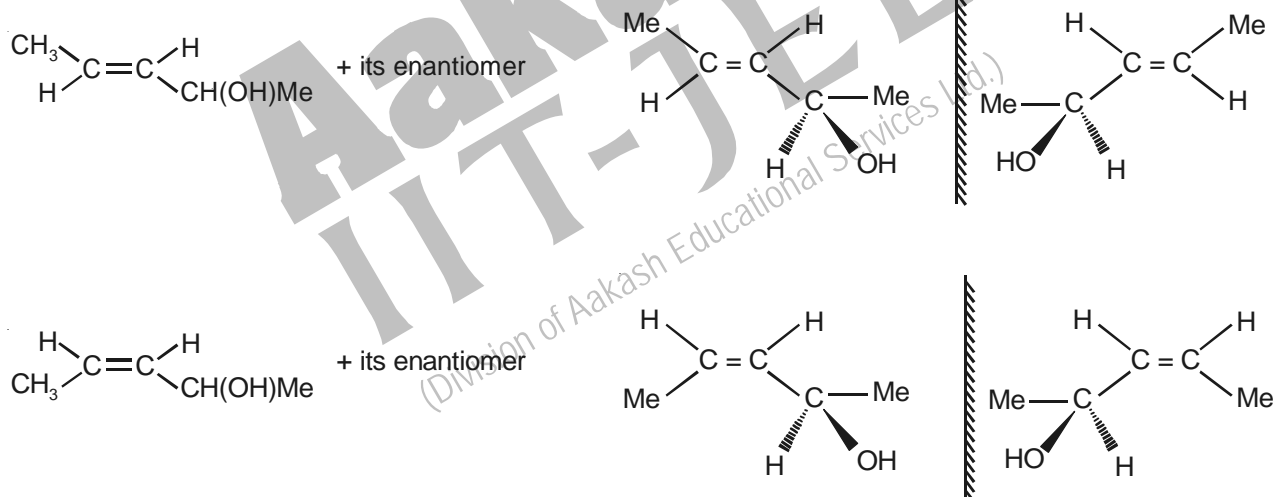

24. In Cannizzaro reaction given below



the slowest step is

- (1) The transfer of hydride to the carbonyl group
 (2) The abstraction of proton from the carboxylic group
 (3) The deprotonation of PhCH_2OH
 (4) The attack of $:\text{OH}^-$ at the carboxyl group

Answer (1)

Hints :

In Cannizzaro reaction, the transfer of hydride to the carbonyl group is the rate determining step.

25. On the basis of the following thermochemical data : ($\Delta_f G^\circ H_{(aq)}^+ = 0$)

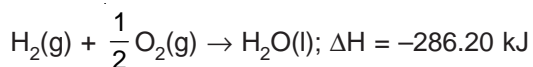

The value of enthalpy of formation of OH^- ion at $25^\circ C$ is

- (1) -228.88 kJ (2) $+228.88 \text{ kJ}$
(3) -343.52 kJ (4) -22.88 kJ

Answer (1)

Hints:

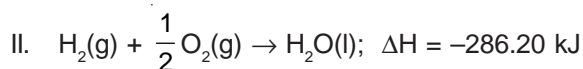

Adding I & II we get,

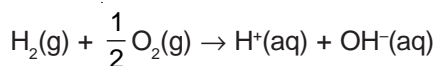

$$\Delta H = 57.32 - 286.2$$
$$= -228.88 \text{ kJ}$$

26. Copper crystallises in fcc with a unit cell length of 361 pm. What is the radius of copper atom?

- (1) 127 pm (2) 157 pm (3) 181 pm (4) 108 pm

Answer (1)

Hints:

$$r = \frac{a}{2\sqrt{2}} = \frac{361}{2\sqrt{2}} = 127.6 \text{ pm}$$

27. In a fuel cell methanol is used as fuel and oxygen gas is used as an oxidizer. The reaction is

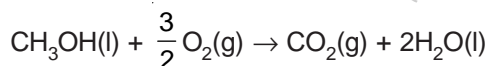

At 298 K standard Gibb's energies of formation for $CH_3OH(l)$, $H_2O(l)$ and $CO_2(g)$ are -166.2 , -237.2 and $-394.4 \text{ kJ mol}^{-1}$ respectively. If standard enthalpy of combustion of methanol is -726 kJ mol^{-1} , efficiency of the fuel cell will be

- (1) 87% (2) 90%
(3) 97% (4) 80%

Answer (3)

Hints:

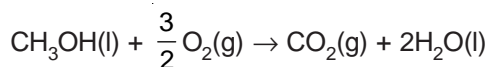

$$\Delta G_{\text{reaction}} = \Delta G_{\text{products}} - \Delta G_{\text{reactant}}$$
$$= [-394.4 - 2 \times 237.2] - [-166.2]$$
$$= -702.6 \text{ kJ}$$

We know, efficiency of a fuel cell, $\eta = \frac{\Delta G}{\Delta H} \times 100$

$$= \frac{-702.6}{-726} \times 100$$

$$\approx 97\%$$

28. Two liquids X and Y form an ideal solution. At 300 K, vapour pressure of the solution containing 1 mol of X and 3 mol of Y is 550 mmHg. At the same temperature, if 1 mol of Y is further added to this solution, vapour pressure of the solution increases by 10 mmHg. Vapour pressure (in mmHg) of X and Y in their pure states will be, respectively

- (1) 300 and 400 (2) 400 and 600
 (3) 500 and 600 (4) 200 and 300

Answer (2)

Hint :

Let V. P. of pure X = x

and V. P. of pure Y = y

Then, $\frac{1}{4}x + \frac{3}{4}y = 550$... (i)

and $\frac{1}{5}x + \frac{4}{5}y = 560$... (ii)

Solving (i) and (ii), we get

$$x = 400 \text{ mm}$$

and $y = 600 \text{ mm}$

29. Given $E_{\text{Fe}^{3+}/\text{Fe}}^0 = -0.036 \text{ V}$, $E_{\text{Fe}^{2+}/\text{Fe}}^0 = -0.439 \text{ V}$

The value of standard electrode potential for the change, $\text{Fe}_{(\text{aq})}^{3+} + e^- \rightarrow \text{Fe}^{2+} (\text{aq})$ will be

- (1) 0.385 V (2) 0.770 V
 (3) -0.270 V (4) -0.072 V

Answer (2)

Hint :

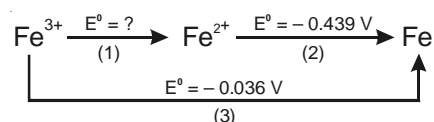

$$\Delta G^0_1 + \Delta G^0_2 = \Delta G^0_3$$

$$\Rightarrow -n_1 E^0_1 - n_2 E^0_2 = -n_3 E^0_3$$

$$\Rightarrow -E^0 + 2 \times 0.439 = +3 \times 0.036$$

$$\Rightarrow E^0 = +0.77 \text{ V}$$

30. The half life period of a first order chemical reaction is 6.93 minutes. The time required for the completion of 99% of the chemical reaction will be ($\log 2 = 0.301$)

- (1) 23.03 minutes (2) 46.06 minutes
 (3) 460.6 minutes (4) 230.3 minutes

Answer (2)

Hint :

$$t_{1/2} = \frac{\ln 2}{k}$$

$$\Rightarrow k = \frac{2.303 \times 0.301}{6.93}$$

$$\text{Also, } t = \frac{2.303}{k} \log \left(\frac{a}{a - 0.99a} \right)$$

$$\Rightarrow t = \frac{2.303}{2.303 \times 0.301} \times 6.93 \log \left(\frac{1}{0.01} \right)$$

$$= 46.05 \text{ minutes}$$

PART - B : MATHEMATICS

Directions : Questions number 31 to 35 are Assertion-Reason type questions. Each of these questions contains two statements :

Statement -1 (Assertion) and Statement-2 (Reason)

Each of these questions also has four alternative choices, only one of which is the correct answer. You have to select the correct choice.

31. **Statement-1 :** $\sim (p \leftrightarrow \sim q)$ is equivalent to $p \leftrightarrow q$.

Statement-2 : $\sim (p \leftrightarrow \sim q)$ is a tautology.

- (1) Statement-1 is true, Statement-2 is true; Statement-2 is **not** a correct explanation for Statement-1
 (2) Statement-1 is true, Statement-2 is false
 (3) Statement-1 is false, Statement-2 is true
 (4) Statement-1 is true, Statement-2 is true; Statement-2 is a correct explanation for Statement-1

Answer (2)

Hint :

p	q	$\sim q$	$p \leftrightarrow (\sim q)$	$\sim [p \leftrightarrow (\sim q)]$	$p \leftrightarrow q$
T	T	F	F	T	T
T	F	T	T	F	F
F	T	F	T	F	F
F	F	T	F	T	T

\therefore Statement (1) is true and statement (2) is false.

32. Let A be a 2×2 matrix

Statement-1 : $\text{adj}(\text{adj } A) = A$

Statement-2 : $|\text{adj } A| = |A|$

- (1) Statement-1 is true, Statement-2 is true; Statement-2 is **not** a correct explanation for Statement-1
(2) Statement-1 is true, Statement-2 is false
(3) Statement-1 is false, Statement-2 is true
(4) Statement-1 is true, Statement-2 is true; Statement-2 is a correct explanation for Statement-1

Answer (1)

Hint :

$$\text{Let } A = \begin{bmatrix} a & b \\ c & d \end{bmatrix}$$

$$\text{Then } \text{adj}(A) = \begin{bmatrix} d & -b \\ -c & a \end{bmatrix}$$

$$\therefore |A| = |\text{adj } A| = ad - bc$$

$$\text{Also } \text{adj}[\text{adj } A] = \begin{bmatrix} a & b \\ c & d \end{bmatrix} = A$$

\therefore Both statements are true but (2) is not correct explanation of (1).

33. Let $f(x) = (x + 1)^2 - 1$, $x \geq -1$.

Statement-1 : The set $\{x : f(x) = f^{-1}(x)\} = \{0, -1\}$.

Statement-2 : f is a bijection.

- (1) Statement-1 is true, Statement-2 is true; Statement-2 is **not** a correct explanation for Statement-1
(2) Statement-1 is true, Statement-2 is false
(3) Statement-1 is false, Statement-2 is true
(4) Statement-1 is true, Statement-2 is true; Statement-2 is a correct explanation for Statement-1

Answer (2)

Hint :

$$\text{We have, } f(x) = (x + 1)^2 - 1, x \geq -1$$

$$\Rightarrow f'(x) = 2(x + 1) \geq 0 \text{ for } x \geq -1$$

$$\Rightarrow f(x) \text{ is one-one}$$

Since co-domain of the given function is not given, hence it can be considered as R , the set of reals and consequently R is not onto.

Hence f is not bijective statement-2 is false.

$$\text{Also } f(x) = (x + 1)^2 - 1 \geq -1 \text{ for } x \geq -1$$

$$\Rightarrow R_f = [-1, \infty)$$

Clearly $f(x) = f^{-1}(x)$ at $x = 0$ and $x = -1$.

Statement-1 is true.

34. **Statement-1** : The variance of first n even natural numbers is $\frac{n^2 - 1}{4}$.

Statement-2 : The sum of first n natural numbers is $\frac{n(n+1)}{2}$ and the sum of squares of first n natural numbers is $\frac{n(n+1)(2n+1)}{6}$.

- (1) Statement-1 is true, Statement-2 is true; Statement-2 is **not** a correct explanation for Statement-1
- (2) Statement-1 is true, Statement-2 is false
- (3) Statement-1 is false, Statement-2 is true
- (4) Statement-1 is true, Statement-2 is true; Statement-2 is a correct explanation for Statement-1

Answer (3)

Hint :

Statement (2) is true.

$$\begin{aligned}\text{var } x &= \frac{\sum x_i^2}{n} - \left(\frac{\sum x_i}{n}\right)^2 \\ &= \frac{4n(n+1)(2n+1)}{6n} - (n+1)^2 \\ &= \frac{2}{3}(n+1)(2n+1) - (n+1)^2 \\ &= \frac{(n+1)}{3}\{4n+2-3n-3\} \\ &= \frac{(n+1)(n-1)}{3} \\ &= \frac{n^2-1}{3}\end{aligned}$$

\therefore Statement (1) is false.

Statement (2) is true.

35. Let $f(x) = x|x|$ and $g(x) = \sin x$.

Statement-1 : $g \circ f$ is differentiable at $x = 0$ and its derivative is continuous at that point.

Statement-2 : $g \circ f$ is twice differentiable at $x = 0$.

- (1) Statement-1 is true, Statement-2 is true; Statement-2 is **not** a correct explanation for Statement-1
- (2) Statement-1 is true, Statement-2 is false
- (3) Statement-1 is false, Statement-2 is true
- (4) Statement-1 is true, Statement-2 is true; Statement-2 is a correct explanation for Statement-1

Answer (2)

Hint :

$$f(x) = x|x| \text{ and } g(x) = \sin x$$

$$(g \circ f)(x) = \begin{cases} -\sin x^2 & x < 0 \\ 0 & x = 0 \\ \sin x^2 & x > 0 \end{cases}$$

For first derivative

$$\begin{aligned} \text{LHD} &= \lim_{x \rightarrow 0^-} \frac{-\sin x^2}{x} = \lim_{x \rightarrow 0^-} \frac{-x \sin x^2}{x^2} = 0 \\ &= 0 \end{aligned}$$

$$\text{RHD} = \lim_{x \rightarrow 0^+} \frac{\sin x^2}{x} \times \frac{x}{x} = 0$$

$\therefore g \circ f$ is differentiable at $x = 0$.

$$(g \circ f)'(x) = \begin{cases} -2x \cos x^2 & x < 0 \\ 0 & x = 0 \\ 2x \cos x^2 & x > 0 \end{cases}$$

For second derivative,

$$\text{LHD} = \lim_{x \rightarrow 0^-} \frac{-2x \cos x^2}{x} = -2$$

$$\text{RHD} = \lim_{x \rightarrow 0^+} \frac{2x \cos x^2}{x} = 2$$

$\therefore (g \circ f)$ is not twice differentiable at $x = 0$.

36. The area of the region bounded by the parabola $(y - 2)^2 = x - 1$, the tangent to the parabola at the point $(2, 3)$ and the x -axis is

- (1) 6 (2) 9
(3) 12 (4) 3

Answer (2)

Hints : The equation of tangent at $(2, 3)$ to the given parabola is $x = 2y - 4$

$$\text{Required area} = \int_0^3 \{(y - 2)^2 + 1 - 2y + 4\} dy$$

$$= \left[\frac{(y - 2)^3}{3} - y^2 + 5y \right]_0^3$$

$$= \frac{1}{3} - 9 + 15 + \frac{8}{3}$$

$$= 9 \text{ sq. units.}$$

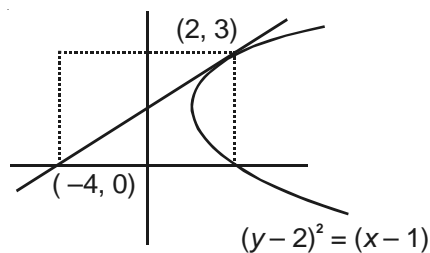

37. Given $P(x) = x^4 + ax^3 + bx^2 + cx + d$ such that $x = 0$ is the only real root of $P'(x) = 0$. If $P(-1) < P(1)$, then in the interval $[-1, 1]$

- (1) $P(-1)$ is not minimum but $P(1)$ is the maximum of P
- (2) $P(-1)$ is minimum but $P(1)$ is not the maximum of P
- (3) Neither $P(-1)$ is the minimum nor $P(1)$ is the maximum of P
- (4) $P(-1)$ is the minimum and $P(1)$ is the maximum of P

Answer (1)

Hints : We have $P(x) = x^4 + ax^3 + bx^2 + cx + d$

$$P'(x) = 4x^3 + 3ax^2 + 2bx + c$$

$$P'(0) = 0 \Rightarrow c = 0$$

Also $P'(x) = 0$ only at $x = 0$

$P'(x)$ is a cubic polynomial changing its sign from (-)ve to (+)ve and passing through O .

$$\therefore P'(x) < 0 \quad \forall x < 0$$

$$P'(x) > 0 \quad \forall x > 0$$

Hence the graph of $P(x)$ is upward concave, where $P'(x) = 0$

Now $P(-1) < P(1)$

$\Rightarrow P(-1)$ cannot be minimum in $[-1, 1]$ as minima in this interval is at $x = 0$.

Hence in $[-1, 1]$ maxima is at $x = 1$

Hence $P(-1)$ is not minimum but $P(1)$ is the maximum of P .

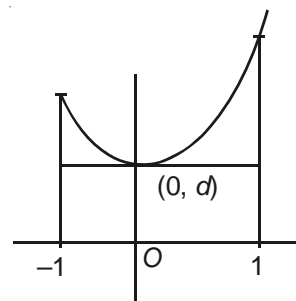

38. The shortest distance between the line $y - x = 1$ and the curve $x = y^2$ is

(1) $\frac{2\sqrt{3}}{8}$

(2) $\frac{3\sqrt{2}}{5}$

(3) $\frac{\sqrt{3}}{4}$

(4) $\frac{3\sqrt{2}}{8}$

Answer (4)

Hints : Let there be a point $P(t^2, t)$ on $x = y^2$

Its distance from $x - y + 1 = 0$ is

$$\left| \frac{t^2 - t + 1}{\sqrt{2}} \right|$$

$$\text{Min } (t^2 - t + 1) \text{ is } \frac{3}{4}$$

$$\text{Shortest distance} = \left| \frac{3}{4\sqrt{2}} \right| = \frac{3\sqrt{2}}{8}$$

39. Let the line $\frac{x-2}{3} = \frac{y-1}{-5} = \frac{z+2}{2}$ lie in the plane $x + 3y - \alpha z + \beta = 0$. Then (α, β) equals

- (1) $(-6, 7)$ (2) $(5, -15)$
 (3) $(-5, 5)$ (4) $(6, -17)$

Answer (1)

Hints : The point $(2, 1, -2)$ is on the plane $x + 3y - \alpha z + \beta = 0$

Hence $2 + 3 + 2\alpha + \beta = 0$

$$2\alpha + \beta = -5 \quad \dots (i)$$

Also $1(3) + 3(-5) - \alpha(2) = 0$

$$3 - 15 - 2\alpha = 0$$

$$2\alpha = -12$$

$$\alpha = -6$$

Put $\alpha = -6$ in (i)

$$\beta = 12 - 5 = 7$$

$$\therefore (\alpha, \beta) = (-6, 7)$$

40. From 6 different novels and 3 different dictionaries, 4 novels and 1 dictionary are to be selected and arranged in a row on a shelf so that the dictionary is always in the middle. Then the number of such arrangements is

- (1) At least 500 but less than 750 (2) At least 750 but less than 1000
 (3) At least 1000 (4) Less than 500

Answer (3)

Hints : The number of ways in which 4 novels can be selected $= {}^6C_4 = 15$

The number of ways in which 1 dictionary can be selected $= {}^3C_1 = 3$

4 novels can be arranged in $4!$ ways.

\therefore The total number of ways $= 15 \times 4! \times 3 = 15 \times 24 \times 3 = 1080$.

41. In a binomial distribution $B\left(n, p = \frac{1}{4}\right)$, if the probability of at least one success is greater than or equal to

$\frac{9}{10}$, then n is greater than

- (1) $\frac{1}{\log_{10} 4 + \log_{10} 3}$ (2) $\frac{9}{\log_{10} 4 - \log_{10} 3}$
 (3) $\frac{4}{\log_{10} 4 - \log_{10} 3}$ (4) $\frac{1}{\log_{10} 4 - \log_{10} 3}$

Answer (4)

45. The differential equation which represents the family of curves $y = c_1 e^{c_2 x}$, where c_1 and c_2 are arbitrary constants, is

- (1) $y'' = y' y$ (2) $yy'' = y'$
 (3) $yy'' = (y')^2$ (4) $y' = y^2$

Answer (3)

Hints : Put $e^{c_2} = k$

Then $y = c_1 \cdot k^x$

$$\Rightarrow \log_e y = \log_e c_1 + x \log_e k$$

$$\Rightarrow \frac{1}{y} y' = \log_e k$$

$$\Rightarrow \frac{1}{y} y'' - \frac{1}{y^2} (y')^2 = 0$$

$$\Rightarrow yy'' = (y')^2$$

46. Let a, b, c be such that $b(a+c) \neq 0$. If $\begin{vmatrix} a & a+1 & a-1 \\ -b & b+1 & b-1 \\ c & c-1 & c+1 \end{vmatrix} + \begin{vmatrix} a+1 & b+1 & c-1 \\ a-1 & b-1 & c+1 \\ (-1)^{n+2} a & (-1)^{n+1} b & (-1)^n c \end{vmatrix} = 0$, then the value

of n is

- (1) Any even integer (2) Any odd integer
 (3) Any integer (4) Zero

Answer (2)

Hints : Applying $D' = D$ is first determinant and $R_2 \leftrightarrow R_3$ and $R_1 \leftrightarrow R_2$ in second determinant

$$\begin{vmatrix} a & -b & c \\ a+1 & b+1 & c-1 \\ a-1 & b-1 & c+1 \end{vmatrix} + \begin{vmatrix} a(-1)^{n+2} & b(-1)^{n+1} & c(-1)^n \\ a+1 & b+1 & c-1 \\ a-1 & b-1 & c+1 \end{vmatrix} = 0$$

$$\text{Then } \begin{vmatrix} a+(-1)^{n+2}a & -b+(-1)^{n+1}b & c+(-1)^n c \\ a+1 & b+1 & c-1 \\ a-1 & b-1 & c+1 \end{vmatrix} = 0 \text{ if } n \text{ is an odd integer.}$$

47. The remainder left out when $8^{2n} - (62)^{2n+1}$ is divided by 9 is

- (1) 2 (2) 7
 (3) 8 (4) 0

Answer (1)

Hints : Put $n = 0$

Then when $1 - 62$ is divided by 9 then remainder is same as when $63 - 61$ is divided by 9 which is 2.

48. Let y be an implicit function of x defined by $x^{2x} - 2x^x \cot y - 1 = 0$. Then $y'(1)$ equals

- (1) 1 (2) $\log 2$
 (3) $-\log 2$ (4) -1

Answer (4)

Hints : $\therefore (x^x)^2 - 2.x^x \cot y = 1, \therefore$ when $x = 1, y = \frac{\pi}{2}$

$$\text{Differentiating, } 2.x^x . x^x (1 + \log_e x) - 2 \left[-x^x \operatorname{cosec}^2 y \frac{dy}{dx} + \cot y . x^x (1 + \log x) \right] = 0$$

Put $x = 1$ and $y = \frac{\pi}{2}$

$$2 + 2 \cdot \frac{dy}{dx} - 2 \times 0 = 0$$

$$\frac{dy}{dx} = -1$$

49. If the roots of the equation $bx^2 + cx + a = 0$ be imaginary, then for all real values of x , the expression $3b^2x^2 + 6bcx + 2c^2$ is

- (1) Less than $4ab$ (2) Greater than $-4ab$
 (3) Less than $-4ab$ (4) Greater than $4ab$

Answer (2)

Hints : $bx^2 + cx + a = 0$

Roots are imaginary $c^2 - 4ab < 0$

$$f(x) = 3b^2x^2 + 6bcx + 2c^2$$

$$D = 36b^2c^2 - 24b^2c^2 = 12b^2c^2$$

$$\therefore 3b^2 > 0$$

$$\therefore f(x) \geq \left(-\frac{D}{4a} \right)$$

$$f(x) \geq -c^2$$

Now $c^2 - 4ab < 0$

$$c^2 < 4ab$$

$$-c^2 > -4ab$$

$$\therefore f(x) > -4ab.$$

50. The sum to infinity of the series $1 + \frac{2}{3} + \frac{6}{3^2} + \frac{10}{3^3} + \frac{14}{3^4} + \dots$ is

- (1) 3 (2) 4 (3) 6 (4) 2

Answer (1)

Hints : Let $S = 1 + \frac{2}{3} + \frac{6}{3^2} + \frac{10}{3^3} + \frac{14}{3^4} + \dots$

$$S - 1 = \frac{2}{3} + \frac{6}{3^2} + \frac{10}{3^3} + \frac{14}{3^4} + \dots$$

$$\frac{S - 1}{3} = \frac{2}{3^2} + \frac{6}{3^3} + \frac{10}{3^4} + \frac{14}{3^5} + \dots$$

$$\Rightarrow \frac{2}{3}(S - 1) = \frac{2}{3} + \frac{4}{3^2} + \frac{4}{3^3} + \frac{4}{3^4} + \dots$$

$$\Rightarrow S - 1 = 1 + \frac{2}{3} + \frac{2}{3^2} + \frac{2}{3^3} + \dots$$

$$\Rightarrow S = 2 + \frac{\frac{2}{3}}{1 - \frac{1}{3}}$$

$$= 2 + 1$$

$$= 3$$

51. The projections of a vector on the three coordinate axis are 6, -3, 2 respectively. The direction cosines of the vector are

(1) $\frac{6}{5}, \frac{-3}{5}, \frac{2}{5}$

(2) $\frac{6}{7}, \frac{-3}{7}, \frac{2}{7}$

(3) $\frac{-6}{7}, \frac{-3}{7}, \frac{2}{7}$

(4) 6, -3, 2

Answer (2)

Hints : Direction ratios are $a = 6$, $b = -3$ and $c = 2$

Then direction cosines are $\frac{6}{\sqrt{36+9+4}}, \frac{-3}{\sqrt{36+9+4}}, \frac{2}{\sqrt{36+9+4}}$

$$= \frac{6}{7}, \frac{-3}{7}, \frac{2}{7}$$

52. Let A and B denote the statements :

A : $\cos\alpha + \cos\beta + \cos\gamma = 0$

B : $\sin\alpha + \sin\beta + \sin\gamma = 0$

If $\cos(\beta - \gamma) + \cos(\gamma - \alpha) + \cos(\alpha - \beta) = -\frac{3}{2}$, then

(1) A is false and B is true

(2) Both A and B are true

(3) Both A and B are false

(4) A is true and B is false

Answer (2)

Hints : $2(\cos\beta \cos\gamma + \sin\beta \sin\gamma) + 2(\cos\gamma \cos\alpha + \sin\gamma \sin\alpha) + 2(\cos\alpha \cos\beta + \sin\alpha \sin\beta)$
 $+ \sin^2\alpha + \cos^2\alpha + \sin^2\beta + \cos^2\beta + \sin^2\gamma + \cos^2\gamma = 0$

$$\Rightarrow (\sin\alpha + \sin\beta + \sin\gamma)^2 + (\cos\alpha + \cos\beta + \cos\gamma)^2 = 0$$

$$\Rightarrow \sin\alpha + \sin\beta + \sin\gamma = 0 = \cos\alpha + \cos\beta + \cos\gamma$$

\therefore Both A and B are true.

53. One ticket is selected at random from 50 tickets numbered 00, 01, 02, ... , 49. Then the probability that the sum of the digits on the selected ticket is 8, given that the product of these digits is zero, equals

(1) $\frac{1}{7}$

(2) $\frac{5}{14}$

(3) $\frac{1}{50}$

(4) $\frac{1}{14}$

Answer (4)

Hints : Restricting sample space as $S = \{00, 01, 02, 03, 04, 05, 06, 07, 08, 09, 10, 20, 30, 40\}$.

$$\therefore P(\text{sum of digits is } 8) = \frac{1}{14}$$

54. Three distinct points A, B and C are given in the 2 - dimensional coordinate plane such that the ratio of the distance of any one of them from the point (1, 0) to the distance from the point (-1, 0) is equal to $\frac{1}{3}$. Then the circumcentre of the triangle ABC is at the point

(1) $\left(\frac{5}{4}, 0\right)$

(2) $\left(\frac{5}{2}, 0\right)$

(3) $\left(\frac{5}{3}, 0\right)$

(4) (0, 0)

Answer (1)

Hints : Let (x, y) denote the coordinates of A, B and C.

$$\text{Then, } \frac{(x-1)^2 + y^2}{(x+1)^2 + y^2} = \frac{1}{9}$$

$$\Rightarrow 9x^2 + 9y^2 - 18x + 9 = x^2 + y^2 + 2x + 1$$

$$\Rightarrow 8x^2 + 8y^2 - 20x + 8 = 0$$

$$x^2 + y^2 - \frac{5}{2}x + 1 = 0$$

\therefore A, B, C lie on a circle with $C\left(\frac{5}{4}, 0\right)$.

55. If the mean deviation of the numbers 1, 1 + d, 1 + 2d,, 1 + 100d from their mean is 255, then the d is equal to

(1) 20.0

(2) 10.1

(3) 20.2

(4) 10.0

Answer (2)

Hints : $\bar{x} = \frac{1 + (1+d) + (1+2d) + \dots + (1+100d)}{101}$

$$\bar{x} = \frac{101 + d(1+2+3+\dots+100)}{101}$$

$$\bar{x} = \frac{101 + d \times \frac{100 \times 101}{2}}{101}$$

$$\bar{x} = 1 + 50d$$

$$\text{Mean deviation} = \frac{|1+50d-1| + |1+50d-1-d| + \dots + |1+50d-1-100d|}{101}$$

$$= \frac{50d + 49d + 48d + \dots + d + 0 + d + 2d + \dots + 50d}{101}$$

$$= \frac{2 \times d \times \left(\frac{50 \times 51}{2}\right)}{101}$$

$$\Rightarrow \frac{50 \times 51 \times d}{101} = 255$$

$$\Rightarrow d = 10.1$$

56. The ellipse $x^2 + 4y^2 = 4$ is inscribed in a rectangle aligned with the coordinate axes, which in turn is inscribed in another ellipse that passes through the point $(4, 0)$. Then the equation of the ellipse is

(1) $x^2 + 12y^2 = 16$

(2) $4x^2 + 48y^2 = 48$

(3) $4x^2 + 64y^2 = 48$

(4) $x^2 + 16y^2 = 16$

Answer (1)

Hints : Let the equation of the required ellipse is

$$\frac{x^2}{16} + \frac{y^2}{b^2} = 1$$

But the ellipse passes through $(2, 1)$

$$\Rightarrow \frac{1}{4} + \frac{1}{b^2} = 1$$

$$\Rightarrow \frac{1}{b^2} = \frac{3}{4}$$

$$\Rightarrow b^2 = \frac{4}{3}$$

Hence equation is

$$\frac{x^2}{16} + \frac{y^2 \times 3}{4} = 1$$

$$\Rightarrow x^2 + 12y^2 = 16$$

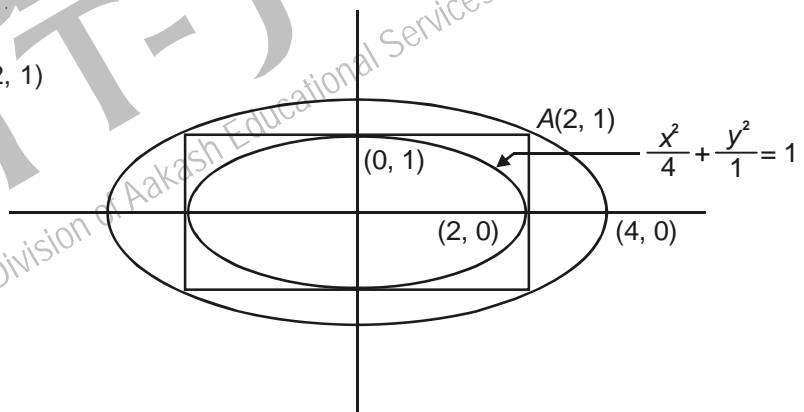

57. If $\left|Z - \frac{4}{Z}\right| = 2$, then the maximum value of $|Z|$ is equal to

(1) $\sqrt{5} + 1$

(2) 2

(3) $2 + \sqrt{2}$

(4) $\sqrt{3} + 1$

Answer (1)

Hints : $\left| z - \frac{4}{z} \right| = 2$

$$\Rightarrow \left| z - \frac{4}{z} \right| \geq \left| |z| - \frac{4}{|z|} \right|$$

$$\Rightarrow \left| |z| - \frac{4}{|z|} \right| \leq 2$$

$$\Rightarrow |z|^2 - 4 - 2|z| \leq 0$$

$$\Rightarrow |z|^2 - 2|z| - 4 \leq 0$$

$$1 - \sqrt{5} \leq |z| \leq 1 + \sqrt{5}$$

Hence maximum value = $1 + \sqrt{5}$

58. If P and Q are the points of intersection of the circles $x^2 + y^2 + 3x + 7y + 2p - 5 = 0$ and $x^2 + y^2 + 2x + 2y - p^2 = 0$, then there is a circle passing through P , Q and $(1, 1)$ for

- (1) All except one value of p
- (2) All except two values of p
- (3) Exactly one value of p
- (4) All values of p

Answer (1)

Hints : $x^2 + y^2 + 3x + 7y + 2p - 5 + \lambda(x^2 + y^2 + 2x + 2y - p^2) = 0$, $\lambda \neq -1$ passes through point of intersection of given circles.

Since it passes through $(1, 1)$, hence

$$7 - 2p + \lambda(6 - p^2) = 0$$

$$\Rightarrow 7 - 2p + 6\lambda - \lambda p^2 = 0$$

If $\lambda = -1$, then $7 - 2p - 6 + p^2 = 0$

$$p^2 - 2p + 1 = 0$$

$$p = 1$$

$\therefore \lambda \neq -1$ hence $p \neq 1$

\therefore All values of p are possible except $p = 1$

59. If $\vec{u}, \vec{v}, \vec{w}$ are non-coplanar vectors and p, q are real numbers, then the equality

$$[3\vec{u}, p\vec{v}, p\vec{w}] - [p\vec{v}, \vec{w}, q\vec{u}] - [2\vec{w}, q\vec{v}, q\vec{u}] = 0 \text{ holds for}$$

- (1) Exactly two values of (p, q)
- (2) More than two but not all values of (p, q)
- (3) All values of (p, q)
- (4) Exactly one value of (p, q)

Answer (4)

Hints : $[3\bar{u} \cdot \bar{p}\bar{v} \cdot \bar{p}\bar{w}] - [p\bar{v} \cdot \bar{w} \cdot q\bar{u}] - [2\bar{w} \cdot q\bar{v} \cdot q\bar{u}]$
 $= 3p^2[\bar{u} \cdot (\bar{v} \times \bar{w})] - pq[\bar{v} \cdot (\bar{w} \times \bar{u})] - 2q^2[\bar{w} \cdot (\bar{v} \times \bar{u})]$
 $\Rightarrow (3p^2 - pq + 2q^2)[\bar{u} \cdot (\bar{v} \times \bar{w})] = 0$
 But $\bar{u} \cdot (\bar{v} \times \bar{w}) \neq 0$
 $\Rightarrow 3p^2 - pq + 2q^2 = 0$
 $\Rightarrow p = q = 0$

60. $\int_0^\pi [\cot x] dx$, where $[\cdot]$ denotes the greatest integer function, is equal to

- (1) 1 (2) -1 (3) $-\frac{\pi}{2}$ (4) $\frac{\pi}{2}$

Answer (3)

Hints : $I = \int_0^\pi [\cot x] dx$

$I = \int_0^\pi [\cot(\pi - x)] dx$

$2I = \int_0^\pi ([\cot x] + [-\cot x]) dx$

$2I = \int_0^\pi (-1) dx = -\pi$

$I = -\frac{\pi}{2}$

PART - C : PHYSICS

61. Consider a rubber ball freely falling from a height $h = 4.9$ m onto a horizontal elastic plate. Assume that the duration of collision is negligible and the collision with the plate is totally elastic.

Then the velocity as a function of time and the height as a function of time will be

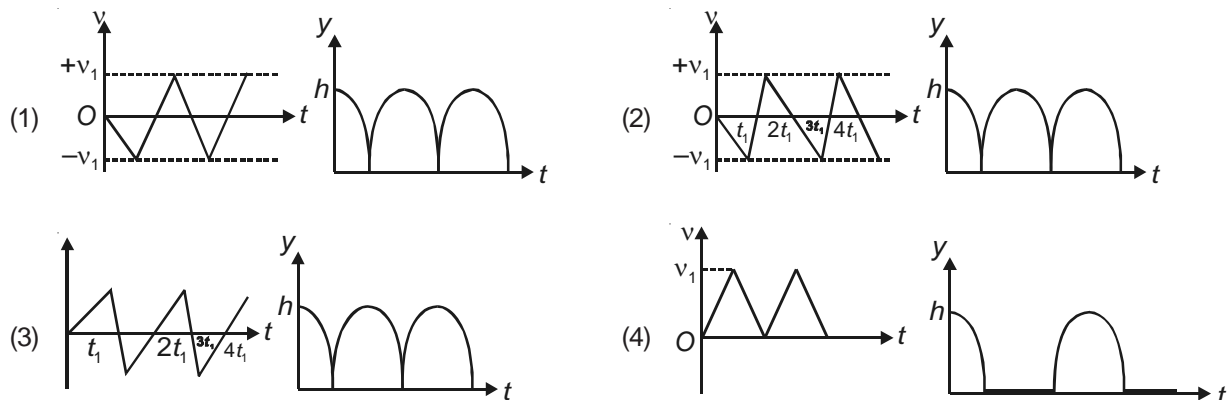

Answer (2)

Hints :

$$\text{From } v = u + at$$

$$v = 0 - g \times t$$

$$\Rightarrow v = -gt$$

And just after collision velocity is upwarded then after some time it becomes zero and then negative. Same process repeats.

$$\text{From } S = ut + \frac{1}{2}at^2$$

$$h = 4.9 - \frac{1}{2}gt^2$$

So, graph will be downward parabola.

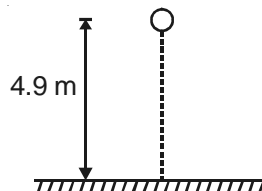

62. The height at which the acceleration due to gravity becomes $\frac{g}{9}$ (where g = the acceleration due to gravity on the surface of the earth) in terms of R , the radius of the earth, is

(1) $\frac{R}{\sqrt{2}}$

(2) $\frac{R}{2}$

(3) $\sqrt{2}R$

(4) $2R$

Answer (4)

Hints :

As,

$$g(h) = \frac{g}{\left(1 + \frac{h}{R}\right)^2}$$

$$\Rightarrow \frac{g}{9} = \frac{g}{\left(1 + \frac{h}{R}\right)^2}$$

$$\Rightarrow \left(1 + \frac{h}{R}\right) = 3$$

$$\Rightarrow \frac{h}{R} = 2 \Rightarrow \boxed{h = 2R}$$

63. A long metallic bar is carrying heat from one of its ends to the other end under steady state. The variation of temperature θ along the length x of the bar from its hot end is best described by which of the following figures?

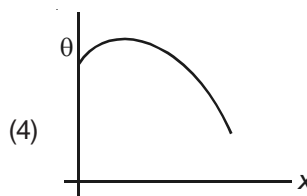
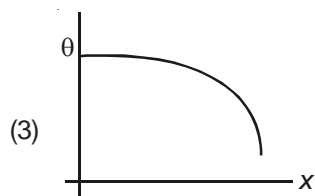
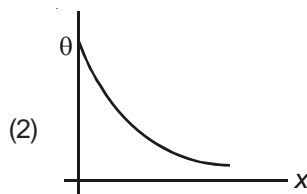
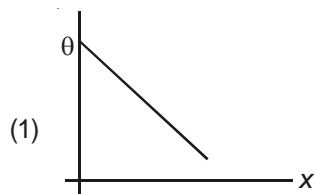

Answer (1)

Hints :

As rate of heat flow through the rod is constant through each section.

$$\frac{T_1 - \theta}{x} = \frac{\theta - T_2}{\ell - x}$$

$$\frac{T_1 - \theta}{k_0 A} = \frac{\theta - T_2}{k_0 A}$$

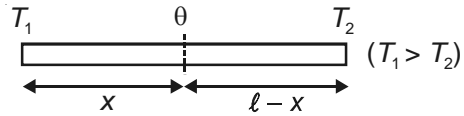

$$\Rightarrow \theta = -\frac{(T_1 - T_2)x}{\ell} + T_1$$

So, graph is

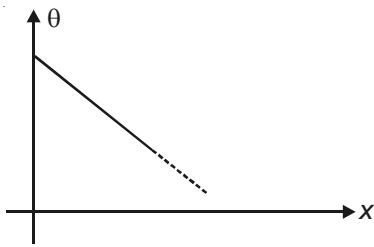

64. Two point P and Q are maintained at the potentials of 10 V and -4 V respectively. The work done in moving 100 electrons from P to Q is

- (1) $9.60 \times 10^{-17}\text{ J}$ (2) $-2.24 \times 10^{-16}\text{ J}$ (3) $2.24 \times 10^{-16}\text{ J}$ (4) $-9.60 \times 10^{-17}\text{ J}$

Answer (3)

Hints :

$$Q = 100e = -100 \times 1.6 \times 10^{-19} = -1.6 \times 10^{-17}\text{ C}$$

$$\Delta V = -14\text{ V}$$

$$\therefore W = Q\Delta V = 14 \times 1.6 \times 10^{-17} = 2.24 \times 10^{-16}\text{ J}$$

Directions : Question numbers 65 and 66 are based on the following paragraph.

A current loop $ABCD$ is held fixed on the plane of the paper as shown in the figure. The arcs BC (radius = b) and DA (radius = a) of the loop are joined by two straight wires AB and CD . A steady current I is flowing in the loop. Angle made by AB and CD at the origin O is 30° . Another straight thin wire with steady current I_1 flowing out of the plane of the paper is kept at the origin.

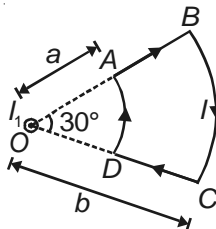

65. The magnitude of the magnetic field (B) due to the loop $ABCD$ at the origin (O) is

- (1) $\frac{\mu_0 I(b-a)}{24ab}$ (2) $\frac{\mu_0 I}{4\pi} \left[\frac{b-a}{ab} \right]$
- (3) $\frac{\mu_0 I}{4\pi} \left[2(b-a) + \frac{\pi}{3}(a+b) \right]$ (4) Zero

Answer (1)

Hints :

Magnetic field due to AB and CD is zero

$$\begin{aligned} \therefore \vec{B}_{\text{net}} &= \frac{\mu_0}{4\pi} \times \frac{I}{a} \times \frac{\pi}{6} \hat{k} + \frac{\mu_0}{4\pi} \times \frac{I}{b} \times \frac{\pi}{6} (-\hat{k}) \\ &= \frac{\mu_0}{24} \times I \left\{ \frac{1}{a} - \frac{1}{b} \right\} \hat{k} \\ &= \frac{\mu_0 I (b-a)}{24ab} \hat{k} \end{aligned}$$

66. Due to the presence of the current I_1 at the origin

(1) The forces on AD and BC are zero

(2) The magnitude of the net force on the loop is given by $\frac{I_1 I}{4\pi} \mu_0 \left[2(b-a) + \frac{\pi}{3}(a+b) \right]$

(3) The magnitude of the net force on the loop is given by $\frac{\mu_0 I_1}{24ab} (b-a)$

(4) The forces on AB and DC are zero

Answer (1)

Hints :

In wire DA

$$\vec{B} \uparrow \uparrow d\vec{\ell}$$

$$\therefore F_{DA} = 0$$

In wire AB , $d\vec{\ell} \times \vec{B}$ is upwards

In wire BC , $\vec{B} \uparrow \downarrow d\vec{\ell} \therefore F_{BC} = 0$

In wire CD , $d\vec{\ell} \times \vec{B}$ is downwards.

Since, AB and CD are symmetrical to I_1

$$\text{So, } \vec{F}_{AB} + \vec{F}_{CD} = 0.$$

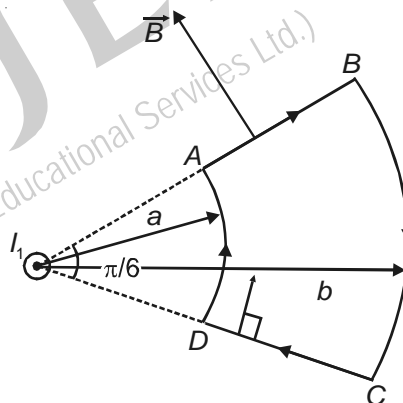

Directions : Question numbers 67, 68 and 69 are based on the following paragraph

Two moles of helium gas are taken over the cycle $ABCD$, as shown in the P - T diagram

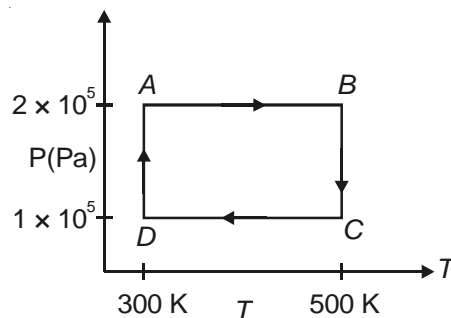

67. Assuming the gas to be ideal the work done on the gas in taking it from A to B is

- (1) $300R$ (2) $400R$ (3) $500R$ (4) $200R$

Answer (2)

Hints :

Since process is isobaric

$$W_{AB} = 2 \times R \times 200 = 400R$$

68. The work done on the gas in taking it from D to A is

- (1) $+414R$ (2) $-690R$ (3) $+690R$ (4) $-414R$

Answer (1)

Hints :

Since process is isothermal

$$\begin{aligned} \therefore W_{DA} &= 2.303 \times 2 \times R \times 300 \log\left(\frac{1}{2}\right) \\ &= -415.8R \text{ J} \end{aligned}$$

So, work done on the gas = $415.8R$ J

Remarks : The exact answer is $415.8R$ J but the option given in the question is approximate.

69. The net work done on the gas in the cycle $ABCD$ is

- (1) $276R$ (2) $1076R$ (3) $1904R$ (4) Zero

Answer (1)

Hints :

$$\begin{aligned} W_{\text{total}} &= W_{DA} + W_{BC}, \text{ since } W_{AB} + W_{CD} = 0 \\ &= 2.303 \times 2 \times R \times 300 \log\left(\frac{1}{2}\right) + 2.303 \times 2 \times R \times 500 \log(2) \\ &= 2.303 \times 2R \times 200 \log(2) \\ &= 277.2R \end{aligned}$$

Remarks : The exact answer is $277.2R$ but the option given in the question is approximate.

70. In an experiment the angles are required to be measured using an instrument. 29 divisions of the main scale exactly coincide with the 30 divisions of the vernier scale. If the smallest division of the main scale is half-a-degree ($= 0.5^\circ$), then the least count of the instrument is

- (1) Half minute (2) One degree (3) Half degree (4) One minute

Answer (4)

Hints :

$$29 \text{ Div of M.S} = 30 \text{ Div of V.S}$$

$$1 \text{ Div of V.S} = \frac{29}{30} \text{ Div of M.S}$$

$$\text{Least count} = 1 \text{ Div of M.S} - 1 \text{ Div V.S}$$

$$= \frac{1}{30} \text{ Div. of M.S}$$

$$= \frac{1}{30} \times \frac{1}{2} = \frac{1}{60^\circ} = 1 \text{ minute}$$

71. A charge Q is placed at each of the opposite corners of a square. A charge q is placed at each of the other two corners. If the net electrical force on Q is zero, then $\frac{Q}{q}$ equals.

(1) -1

(2) 1

(3) $-\frac{1}{\sqrt{2}}$

(4) $-2\sqrt{2}$

Answer (4)

Hints :

Either of Q or q must be negative for equilibrium.

$$\sqrt{2} \frac{kQq}{r^2} = \frac{kQ^2}{2l^2}$$

$$\frac{|Q|}{|q|} = 2\sqrt{2}$$

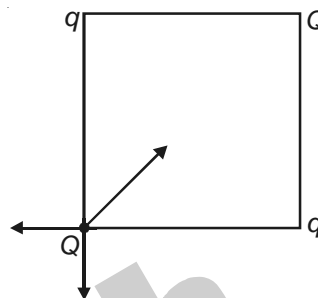

72. One kg of diatomic gas is at a pressure of $8 \times 10^4 \text{ N/m}^2$. The density of the gas is 4 kg/m^3 . What is the energy of the gas due to its thermal motion?

(1) $5 \times 10^4 \text{ J}$

(2) $6 \times 10^4 \text{ J}$

(3) $7 \times 10^4 \text{ J}$

(4) $3 \times 10^4 \text{ J}$

Answer (1)

Hints :

$$E = \frac{f}{2} PV$$

$$E = \frac{5}{2} PV$$

$$= \frac{5}{2} \times P \times \frac{m}{\rho}$$

$$= \frac{5 \times 8 \times 10^4 \times 1}{2 \times 4} = 5 \times 10^4 \text{ J}$$

73. An inductor of inductance $L = 400 \text{ mH}$ and resistors of resistances $R_1 = 2 \Omega$ and $R_2 = 2 \Omega$ are connected to a battery of emf 12 V as shown in the figure. The internal resistance of the battery is negligible. The switch S is closed at $t = 0$. The potential drop across L as a function of time is

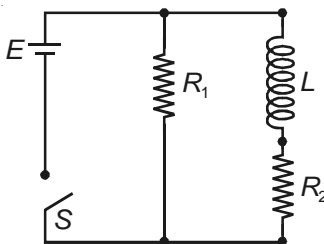

(1) $\frac{12}{t} e^{-3t} \text{ V}$

(2) $6(1 - e^{-t/0.2}) \text{ V}$

(3) $12 e^{-5t} \text{ V}$

(4) $6 e^{-5t} \text{ V}$

Answer (3)**Hints :**

Given circuit is

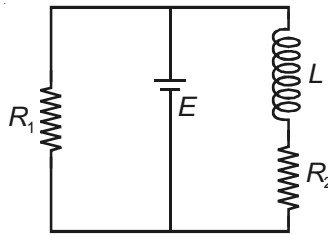

I through inductor as a function of time is

$$I = \frac{E}{R_2} \left\{ 1 - e^{-t/LR_2} \right\}$$

$$V_L = L \frac{dI}{dt} = E e^{-\frac{R_2 t}{L}}$$

$$= 12 e^{-5t}$$

74. **Statement 1:** The temperature dependence of resistance is usually given as $R = R_0(1 + \alpha\Delta t)$. The resistance of a wire changes from 100Ω to 150Ω when its temperature is increased from 27°C to 227°C . This implies that $\alpha = 2.5 \times 10^{-3}/^\circ\text{C}$.

Statement 2: $R = R_0(1 + \alpha\Delta t)$ is valid only when the change in the temperature ΔT is small and $\Delta R = (R - R_0) \ll R_0$.

- (1) Statement 1 is true, statement 2 is true; Statement 2 is the correct explanation of Statement 1
- (2) Statement 1 is true, Statement 2 is true; Statement 2 is not the correct explanation of Statement 1
- (3) Statement 1 is false, Statement 2 is true
- (4) Statement 1 is true, Statement 2 is false

Answer (3)**Hints :**

As relation $R = R_0(1 + \alpha\Delta t)$ is valid only when $\Delta R \ll R_0$.

Hence statement 1 is false and statement 2 is true.

75. The transition from the state $n = 4$ to $n = 3$ in a hydrogen like atom results in ultraviolet radiation. Infrared radiation will be obtained in the transition from

- | | |
|-----------------------|-----------------------|
| (1) $3 \rightarrow 2$ | (2) $4 \rightarrow 2$ |
| (3) $5 \rightarrow 4$ | (4) $2 \rightarrow 1$ |

Answer (3)**Hints :**

Energy gap between 4^{th} and 3^{rd} state is more than the gap between 5^{th} and 4^{th} state,

$$\text{And } \Delta E = \frac{hc}{\lambda}$$

$$\lambda_{5-4} > \lambda_{4-3}$$

76. A mixture of light, consisting of wavelength 590 nm and an unknown wavelength, illuminates Young's double slit and gives rise to two overlapping interference patterns on the screen. The central maximum of both lights coincide. Further, it is observed that the third bright fringe of known light coincides with the 4th bright fringe of the unknown light. From this data, the wavelength of the unknown light is

- (1) 885.0 nm (2) 442.5 nm
 (3) 776.8 nm (4) 393.4 nm

Answer (2)

Hints :

As 4th bright fringe of unknown wavelength coincides with 3rd bright fringe of known wavelength

$$\Rightarrow \frac{4\lambda D}{d} = 3 \frac{(590 \text{ nm})D}{d}$$

$$\Rightarrow \lambda = \frac{3 \times 590}{4} = 442.5 \text{ nm}$$

77. A particle has an initial velocity of $3\hat{i} + 4\hat{j}$ and an acceleration of $0.4\hat{i} + 0.3\hat{j}$. Its speed after 10 s is

- (1) $7\sqrt{2}$ units (2) 7 units
 (3) 8.5 units (4) 10 units

Answer (1)

Hints :

$$\vec{v} = \vec{u} + \vec{a}t$$

$$= (3\hat{i} + 4\hat{j}) + 10(0.4\hat{i} + 0.3\hat{j})$$

$$= (3\hat{i} + 4\hat{j}) + (4\hat{i} + 3\hat{j})$$

$$= 7\hat{i} + 7\hat{j}$$

$$|\vec{v}| = 7\sqrt{2} \text{ units}$$

78. The surface of a metal is illuminated with the light of 400 nm. The kinetic energy of the ejected photoelectrons was found to be 1.68 eV. The work function of the metal is

- (1) 1.41 eV (2) 1.51 eV
 (3) 1.68 eV (4) 3.09 eV

Answer (1)

Hints :

According to enstein photo electric equation

$$\frac{hc}{\lambda} - \phi = K_{\max}$$

$$\Rightarrow (3.10 \text{ eV} - 1.68 \text{ eV}) = K_{\max}$$

$$\Rightarrow K_{\max} = 1.42 \text{ eV}$$

79. Three sound waves of equal amplitudes have frequencies $(\nu - 1)$, ν , $(\nu + 1)$. They superpose to give beats. The number of beats produced per second will be

- (1) 3 (2) 2 (3) 1 (4) 4

Answer (3)

If we assume that all the three waves are in same phase at $t = 0$ they will be again in same phase at $t = 1$

80. A motor cycle starts from rest and accelerates along a straight path at 2 m/s^2 . At the starting point of the motor cycle there is a stationary electric siren. How far has the motor cycle gone when the driver hears the frequency of the siren at 94% of its value when the motor cycle was at rest ? (Speed of sound = 330 ms^{-1})

- (1) 98 m
(2) 147 m
(3) 196 m
(4) 49 m

Answer (1)

Hints :

$$f = f \left(\frac{v - v_0}{v} \right) \quad \left(\begin{array}{l} v = \text{speed of sound} \\ v_0 = \text{speed of observer} \end{array} \right)$$

$$\Rightarrow 0.94 = 1 - \frac{v_0}{v}$$

$$\Rightarrow \frac{v_0}{v} = 0.06$$

$$\Rightarrow v_0 = 19.8 \text{ m/s}$$

$$\Rightarrow \text{Distance covered} = \frac{v_0^2}{2a} = 98 \text{ m}$$

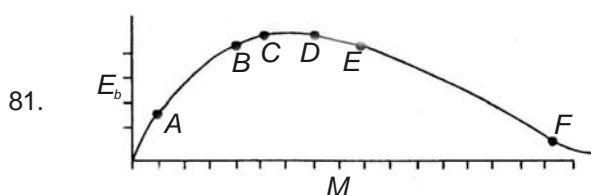

The above is a plot of binding energy per nucleon E_b , against the nuclear mass M ; A, B, C, D, E, F correspond to different nuclei. Consider four reactions :

- (i) $A + B \rightarrow C + \varepsilon$ (ii) $C \rightarrow A + B + \varepsilon$ (iii) $D + E \rightarrow F + \varepsilon$ (iv) $F \rightarrow D + E + \varepsilon$

where ε is the energy released? In which reactions is ε positive?

- (1) (i) and (iii) (2) (ii) and (iv)
(3) (ii) and (iii) (4) (i) and (iv)

Answer (4)

Hints : In reactions (i) & (iv), The B.E per nucleon increases. This makes nuclei more stable so energy will be released in these reactions.

82. A transparent solid cylindrical rod has a refractive index of $\frac{2}{\sqrt{3}}$. It is surrounded by air. A light ray is incident at the mid-point of one end of the rod as shown in the figure.

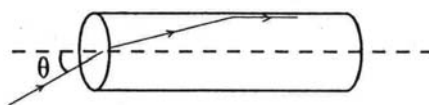

The incident angle θ for which the light ray grazes along the wall of the rod is

- (1) $\sin^{-1}\left(\frac{\sqrt{3}}{2}\right)$ (2) $\sin^{-1}\left(\frac{2}{\sqrt{3}}\right)$ (3) $\sin^{-1}\left(\frac{1}{\sqrt{3}}\right)$ (4) $\sin^{-1}\left(\frac{1}{2}\right)$

Answer (3)

Hints :

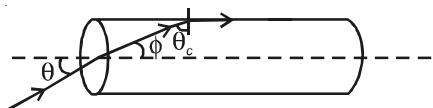

$$i + \theta_c = 90^\circ \quad \theta_c = \sin^{-1}\left(\frac{1}{\mu}\right)$$

Using snell's law

$$\frac{\sin \theta}{\sin \phi} = \mu$$

$$\Rightarrow \sin \theta = \mu \cos \theta_c$$

$$\Rightarrow \sin \theta = \mu \sqrt{1 - \frac{1}{\mu^2}} = \sqrt{\mu^2 - 1}$$

$$\Rightarrow \theta = \sin^{-1}\left(\frac{1}{\sqrt{3}}\right)$$

83. Two wires are made of the same material and have the same volume. However wire 1 has cross-sectional area A and wire 2 has cross-sectional area $3A$. If the length of wire 1 increases by Δx on applying force F , how much force is needed to stretch wire 2 by the same amount ?

- (1) $4F$ (2) $6F$ (3) $9F$ (4) F

Answer (3)

Hints :

$$\frac{F}{A} = Y \frac{\Delta l}{l}$$

$$\Rightarrow F = Y \frac{\Delta l A^2}{Al} = Y \frac{\Delta l A^2}{V}$$

$$\Rightarrow F \propto A^2$$

$$\Rightarrow \frac{F}{F'} = \frac{1}{9}$$

$$\Rightarrow F' = 9F$$

This question contains Statement-1 and statement-2. Of the four choices given after the statements, choose the one that best describes the two statements.

84. **Statement 1** : For a charged particle moving from point P to point Q , the net work done by an electrostatic field on the particle is independent of the path connecting point P to point Q .

Statement 2 : The net work done by a conservative force on an object moving along a closed loop is zero.

- (1) Statement-1 is true, Statement-2 is true; Statement-2 is the correct explanation of Statment-1.
- (2) Statment-1 is true, Statement-2 is true; Statement-2 is not the correct explanation of Statement-1.
- (3) Statement-1 is false, Statement-2 is true.
- (4) Statement-1 is true, Statement-2 is false.

Answer (1)

Hints :

$W_e = -q(V_f - V_i)$ It depends on initial and final point only, because electrostatic field is a conservative field.

85. The logic circuit shown below has the input waveforms 'A' and 'B' as shown. Pick out the correct output waveform.

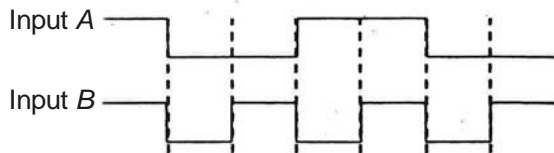
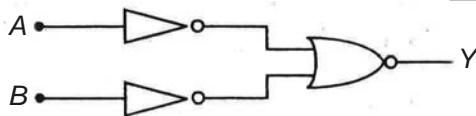

Output is :

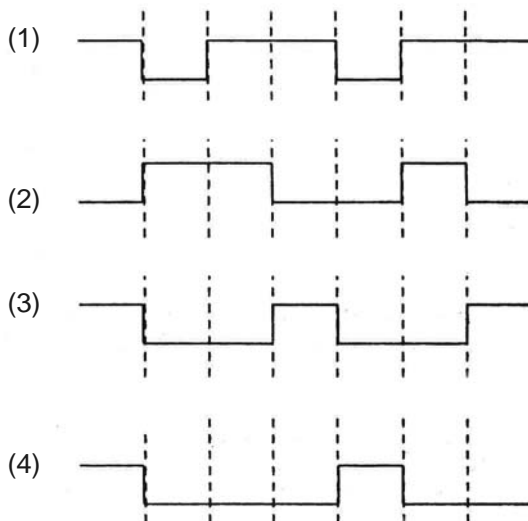

Answer (4)

Hint

$$y = (\overline{A+B}) = A \cdot B$$

The combination represents AND Gate Truth table.

A	B	Y
0	0	0
0	1	0
1	0	0
1	1	1

86. If x , v and a denote the displacement, the velocity and the acceleration of a particle executing simple harmonic motion of time period T , then, which of the following does not change with time ?

- (1) aT/x (2) $aT + 2\pi v$
 (3) aT/v (4) $a^2T^2 + 4\pi^2v^2$

Answer (1)**Hint**

$$x = A \sin(\omega t + \phi)$$

$$a = -A\omega^2 \sin(\omega t + \phi)$$

$$\text{So } \frac{aT}{x} = -\omega^2 T \quad (\text{which is constant})$$

87. A thin uniform rod of length l and mass m is swinging freely about a horizontal axis passing through its end. Its maximum angular speed is ω . Its centre of mass rises to a maximum height of

- (1) $\frac{1}{6} \frac{l\omega}{g}$ (2) $\frac{1}{2} \frac{l^2\omega^2}{g}$ (3) $\frac{1}{6} \frac{l^2\omega^2}{g}$ (4) $\frac{1}{3} \frac{l^2\omega^2}{g}$

Answer (3)**Hints :**

Loss in kinetic energy = Gain in potential energy

$$\frac{1}{2} l\omega^2 = mgh$$

$$\Rightarrow \frac{1}{2} \left(\frac{ml^2}{3} \right) \omega^2 = mgh \Rightarrow h = \frac{l^2\omega^2}{6g}$$

88. In an optics experiment, with the position of the object fixed, a student varies the position of a convex lens and for each position, the screen is adjusted to get a clear image of the object. A graph between the object distance u and the image distance v , from the lens, is plotted using the same scale for the two axes. A straight line passing through the origin and making an angle of 45° with the x -axis meets the experimental curve at P . The coordinates of P will be:

- (1) $\left(\frac{f}{2}, \frac{f}{2} \right)$ (2) (f, f) (3) $(4f, 4f)$ (4) $(2f, 2f)$

Answer (4)

Hints :

At point P

$$|u| = |v| = x$$

$$\text{Since } \frac{1}{v} - \frac{1}{u} = \frac{1}{f}$$

$$\Rightarrow u = 2f$$

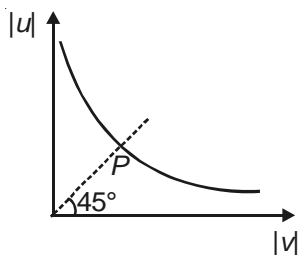

89. A p - n junction (D) shown in the figure can act as a rectifier. An alternating current source (V) is connected in the circuit.

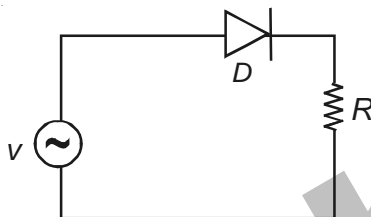

The current (I) in the resistor (R) can be shown by:

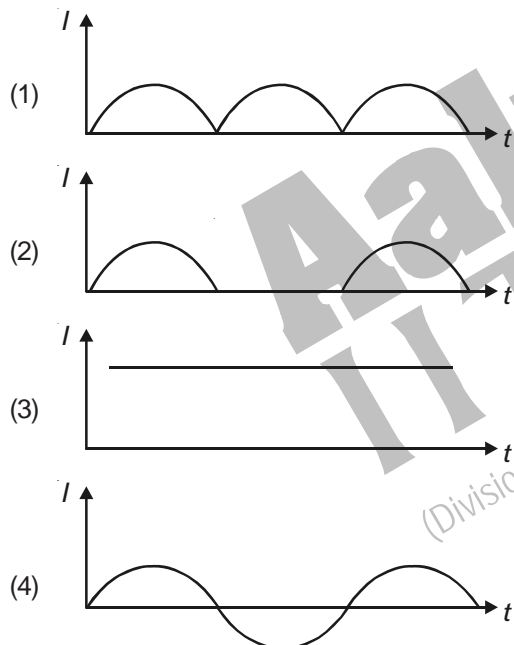

Answer (2)

Hints :

Let input be

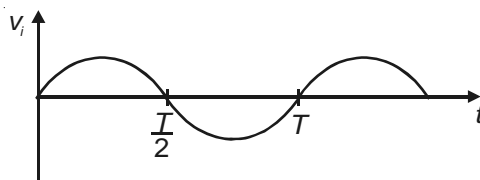

From $0 - \frac{T}{2}$

Diode is in forward bias so there will be current

From $\frac{T}{2} - T$

Diodes is in reverse bias so current through resistor will be zero.

90. Let $\rho(r) = \frac{Q}{\pi R^4} r$ be the charge density distribution for a solid sphere of radius R and total charge Q . For a point 'p' inside the sphere at distance r_1 from the centre of the sphere, the magnitude of electric field is:

- (1) $\frac{Q}{4\pi\epsilon_0 r_1^2}$ (2) $\frac{Q r_1^2}{4\pi\epsilon_0 R^4}$ (3) $\frac{Q r_1^2}{3\pi\epsilon_0 R^4}$ (4) 0

Answer (2)

Hints :

Consider a gaussian surface of radius r_1

$$\oint \vec{E} \cdot \vec{dA} = \frac{Q_{en}}{\epsilon_0}$$

$$E 4\pi r_1^2 = \frac{1}{\epsilon_0} \int \rho dV$$

$$= \frac{1}{\epsilon_0} \int_0^{r_1} \frac{Q r}{\pi R^4} 4\pi r^2 dr$$

$$E = \frac{Q r_1^4}{4\pi\epsilon_0 R^4 r_1^2} = \frac{Q r_1^2}{4\pi\epsilon_0 R^4}$$

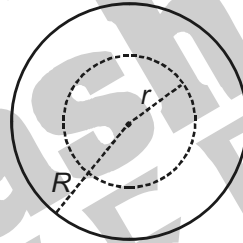

Aakash
IIT-JEE
(Division of Aakash Educational Services Ltd.)